



## DISTRIBUTOR GEAR INSTALLATION INSTRUCTIONS ON FORD PINNED THRUST COLLAR DISTRIBUTORS (EXCEPT FE FORD DISTRIBUTORS)

Please read and follow all instructions before attempting to install distributor gear.

- WARNING:** 1) High volume oil pumps cause severe and excessive gear wear.  
2) Incorrect installation will damage the gear, distributor and / or engine block.

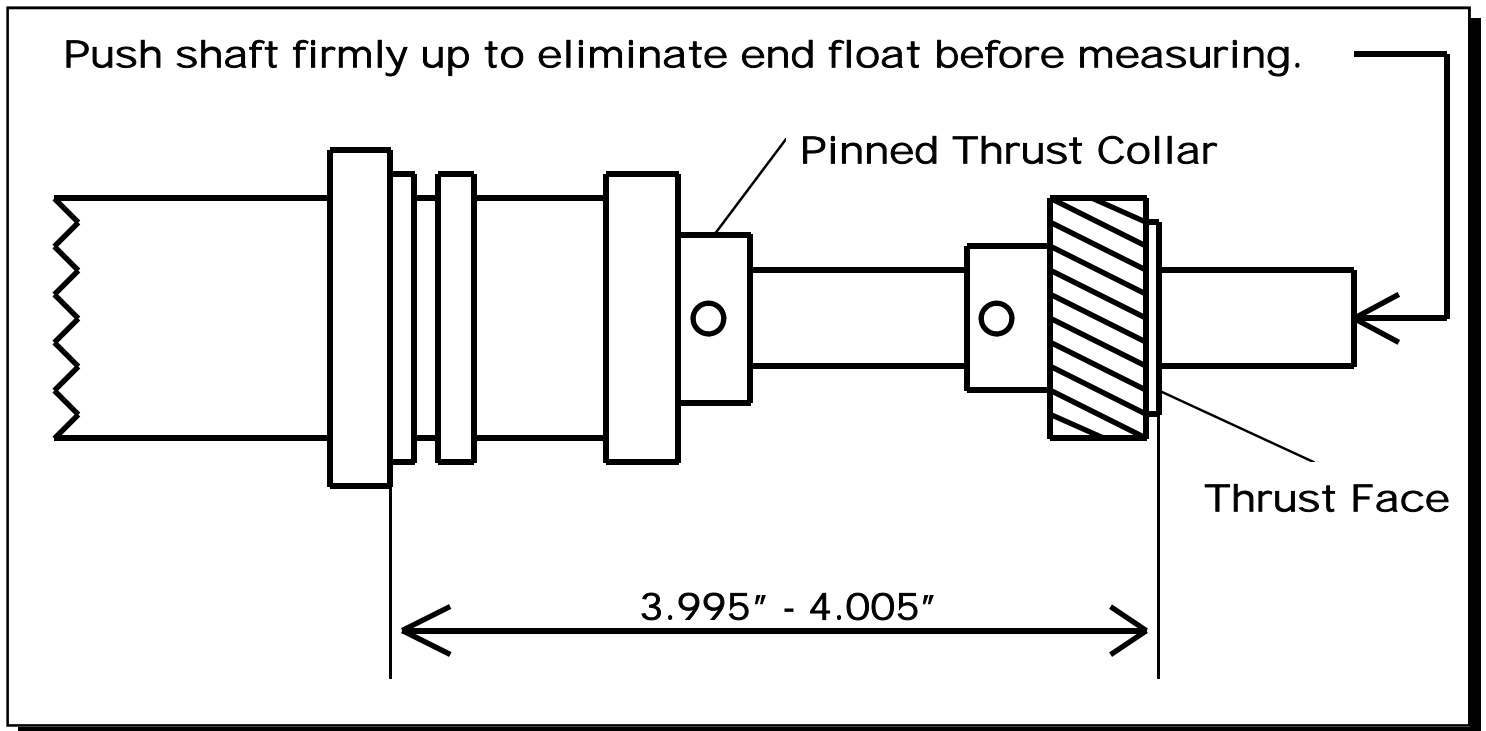

Diagram 1: Correctly installed distributor gear dimensions

- 1) Measure from thrust face to center of roll pin hole in original gear.
- 2) Transfer this measurement to new gear.
- 3) Mark and drill through one side of gear only to size of original hole (1/8 or 3/16).
- 4) Fit gear to shaft and push drill bit through gear into shaft.
- 5) Check dimensions as in Diagram 1.
- 6) If correct, complete drilling 1/8 or 3/16 hole through gear.
- 7) Install new roll pin.

**NOTE:** Any further questions should be directed to the above contact details.